



CLEMCO
The Performance System

TECHNICAL DATA SHEET

Note: For safe, efficient blasting, read and follow the owner's manual and seek training for everyone who will use this equipment.

Purpose

A blast nozzle accelerates the air and abrasive as the mixture exits the end of the hose. The taper and length of the nozzle's inlet and outlet determine the pattern and velocity of the abrasive exiting the nozzle. The composition of the liner material determines its resistance to wear.

Requirements for Operation

Nozzles are sized by the diameter of their orifices (*the narrowest inside diameter*) in 1/16-inch increments. A No. 2 nozzle has a 2/16-inch (1/8-inch) orifice, a No. 3 nozzle has a 3/16-inch orifice, etc. The size of the nozzle orifice determines abrasive and air consumption. Air consumption is measured in cubic feet per minute (cfm) at a given pressure. See the air and abrasive consumption chart on the back of this page.

When choosing a nozzle, consider the amount of available air in cfm, the capacity of the blast machine and the inside diameter of the piping, and the blast and air hoses. For optimal performance, these elements must be compatibly sized. See the compatibility guide on the back of this page.

If too large a nozzle for the compressor is used, low blast pressure will occur. If too large a nozzle for the blast hose is used, rapid wear on the blast hose will occur. If too small a nozzle is used, smooth media flow will be difficult to achieve.

Description of Operation

The operator inserts the nozzle washer into a holder and screws in the nozzle, turning it by hand, until it seats firmly against the washer.

Description

Blast nozzle with venturi shaped Clemlite® silicon-carbide liner, rubber jacket, aluminum or brass threads. Thread size and entry dimensions vary with nozzle series. Includes one nozzle washer.

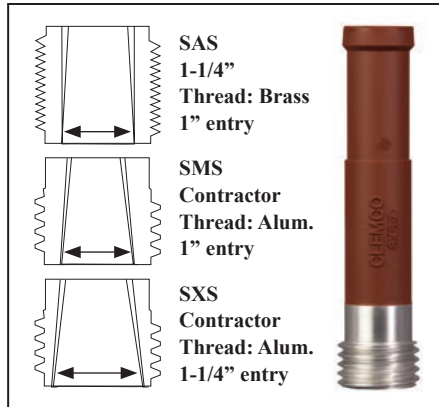

With all related equipment correctly assembled and tested, the operator points the nozzle toward the surface to be blasted and presses the remote control handle to begin blasting. The operator holds the nozzle and moves it smoothly at a rate that produces the desired cleanliness. Each pass should overlap slightly.

The operator must replace the nozzle once the orifice wears 1/16-inch beyond its original size.

Advantages

- Long-venturi nozzles allow high production blasting at a distance of 18 to 24 inches for hard-to-clean surfaces, and 30 to 36 inches for loose paint and soft surfaces

Nozzles

Clemlite® Silicon-Carbide-Lined Rubber-Jacketed

Long-Venturi Style

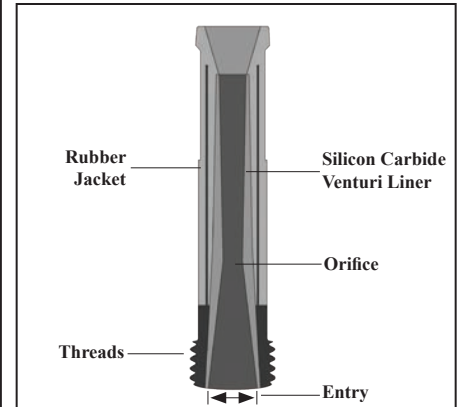

Specifications			
Nozzle Model	SAS	SMS	SXS
Mounting Thread	1-1/4"	Contractor	Contractor
Thread Material	Brass	Aluminum	Aluminum
Entry Diameter	1"	1"	1-1/4"
Liner	Silicon Carbide, Clemlite®		
Liner Style	Venturi		
Jacket Material	Rubber		
Nozzle Color	Brown Jacket		

- Expected life with expendable abrasives is approximately 500 hours
- Durable rubber jacket
- 1-inch entry provides smooth transition and maximum productivity with 1-inch ID blast hose
- 1-1/4-inch entry ensures maximum productivity with 1-1/4-inch ID blast hose



Aluminum Contractor Thread

Brass 1-1/4" Thread

Component Compatibility Guide

No.	Nozzle Orifice	Recommended cfm Range	Min. Blast Machine Capacity	Min. Piping ID	Blast Hose ID	Min. Air Hose ID
4	1/4"	81-137	2ft ³	1"	1" or 1-1/4"	1-1/4"
5	5/16"	137-196	3ft ³	1"	1" or 1-1/4"	1-1/4"
6	3/8"	196-254	6ft ³	1-1/4"	1-1/4"	1-1/2"
7	7/16"	254-338	6ft ³	1-1/4"	1-1/4" or 1-1/2"	2"
8	1/2"	338-548	6ft ³	1-1/4"	1-1/2"	2"

Compressed Air and Abrasive Consumption

Nozzle Orifice	Pressure at the Nozzle (psi)								Air (in cfm) Abrasive & HP Requirements
	50	60	70	80	90	100	125	140	
No. 4 (1/4")	47	54	61	68	74	81	98	110	Air (cfm)
	2.68	3.12	3.54	4.08	4.48	4.94	6.08	6.81	Abrasive (cu.ft/hr & Lbs/hr)
	268	312	354	408	448	494	608	681	Compressor hp
No. 5 (5/16")	77	89	101	113	126	137	168	188	Air (cfm)
	4.68	5.34	6.04	6.72	7.40	8.12	9.82	11.0	Abrasive (cu.ft/hr & Lbs/hr)
	468	534	604	672	740	812	982	1100	Compressor hp
No. 6 (3/8")	108	126	143	161	173	196	237	265	Air (cfm)
	6.68	7.64	8.64	9.60	10.52	11.52	13.93	15.60	Abrasive (cu.ft/hr & Lbs/hr)
	668	764	864	960	1052	1152	1393	1560	Compressor hp
No. 7 (7/16")	147	170	194	217	240	254	314	352	Air (cfm)
	8.96	10.32	11.76	13.12	14.48	15.84	19.31	21.63	Abrasive (cu.ft/hr & Lbs/hr)
	896	1032	1176	1312	1448	1584	1931	2163	Compressor hp
No. 8 (1/2")	195	224	252	280	309	338	409	458	Air (cfm)
	11.60	13.36	15.12	16.80	18.56	20.24	24.59	27.54	Abrasive (cu.ft/hr & Lbs/hr)
	1160	1336	1512	1680	1856	2024	2459	2754	Compressor hp

Nozzle Stock Number, Dimensions & Weights

	Model #	Stock #	Orifice		Net Wt.	Pkg'd Wt.	Holder	Washer
			ID	Length				
Fine 1-1/4" Thread	SAS-4	28079	1/4"	5-3/4"	.95 lb	1.0 lb	HEP Series	NW-4
	SAS-5	28080	5/16"	6-1/8"	1.0 lb	1.1 lb		NW-4
	SAS-6	28081	3/8"	7-1/8"	1.15 lb	1.2 lb		NW-4
	SAS-7	28082	7/16"	8-1/2"	1.30 lb	1.5 lb		NW-4
	SAS-8	28083	1/2"	9-1/2"	1.45 lb	1.5 lb		NW-4
Contractor Thread	SMS-4	100864	1/4"	5-3/4"	.70 lb	1.0 lb	NHP Series	NW-25
	SMS-5	100865	5/16"	6-1/8"	.75 lb	1.0 lb		NW-25
Contractor Thread	SXS-6	100866	3/8"	7-1/8"	.90 lb	1.0 lb	NHP Series	NW-32
	SXS-7	100867	7/16"	8-1/2"	1.10 lb	1.5 lb		NW-32
	SXS-8	100868	1/2"	9-1/2"	1.20 lb	1.5 lb		NW-32

Packaging

Boxed individually

Note: Best performance is obtained when sizes of nozzle, blast machine piping, blast hose and air hose are properly matched.

- Cfm range is based on blasting at 100 psi for the life of the nozzle.
- Blast machine capacity should allow 20 to 30 minutes of blasting.
- Hose ID should be three to four times the size of the nozzle orifice.

Chart shows air consumption in cubic feet per minute (cfm), abrasive consumption in pounds per hour and cubic feet per hour for abrasives weighing 100 pounds per cubic foot, and compressor horsepower (hp) based on 4 to 4.5 cfm per horsepower.

NOTE: Air consumption may vary depending upon working conditions. To maintain desired air pressure as nozzle orifice wears, air consumption increases. The effects of nozzle wear on air consumption must be considered when selecting nozzles and the compressors that support them.

When using nozzles with orifices 3/8-inch or larger, blast machine valves and piping must be 1-1/4-inch or larger to provide sufficient air volume.

Authorized Distributor:



ISO 9001 certified. Clemco is committed to continuous product improvement. Specifications are subject to change without notice.
 ©2017 Clemco Industries Corp. • One Cable Car Drive • Washington, MO 63090 • Phone: 636.239.4300 • Fax: 800.726.7559