



**CMS-2
CARBON MONOXIDE MONITOR
O. M. 22925**

**DATE OF ISSUE: 07/00
REVISION: G, 08/14**

 WARNING

Do not use this equipment until you have READ this MANUAL and YOU UNDERSTAND its contents. *

These WARNINGS are included for the health and safety of the operator and those in the immediate vicinity.

***If you are using a Clemco Distributor Maintenance and Parts Guide, refer to the orange warnings insert preceding the Index before continuing with the enclosed instructions.**

Electronic files include a Preface containing important information.

© 2014 CLEMCO INDUSTRIES CORP.
One Cable Car Dr.
Washington, MO 63090
Phone (636) 239-4300
Fax (800) 726-7559
Email: info@clemcoindustries.com
www.clemcoindustries.com



WARNING

- Employers are responsible for identifying all job site hazards, educating and training all persons who will operate and maintain these products, and ensuring that all blast operators and their assistants understand the warnings and information contained in these instructions relating to safe and proper operation and maintenance of this equipment.
- Serious injury or death can result from failure to comply with all Occupational Safety and Health Administration (OSHA) regulations and all manufacturer's instructions.
- This equipment is not intended for use in any area considered hazardous per National Electric Code NFPA 70 2011, Article 500.
- Read this document and follow all instructions before using this equipment.

OSHA regulations relating to abrasive blasting are contained in the Code of Federal Regulations, Title 29 (29 CFR 1910 General Industry; 1915 Maritime; 1926 Construction). The most pertinent include: 1910.94 Ventilation, 1910.95 Occupational Noise Exposure, 1910.132 Personal Protective Equipment, 1910.133 Eye and Face Protection, 1910.134 Respiratory Protection, 1910.135 Head Protection, 1910.244 (b) Remote Controls. Consult www.osha.gov for complete information.

NOTICE TO PURCHASERS AND USERS OF OUR PRODUCTS AND THIS INFORMATIONAL MATERIAL

Clemco proudly provides products for the abrasive blast industry and is confident that industry professionals will use their knowledge and expertise for the safe and efficient use of these products.

The products described in this material, and the information relating to these products, are intended for knowledgeable, experienced users.

No representation is intended or made as to: the suitability of the products described here for any purpose or application, or to the efficiency, production rate, or useful life of these products. All estimates regarding production rates or finishes are the responsibility of the user and must be derived solely from the user's experience and expertise, not from information contained in this material.

It is possible that the products described in this material may be combined with other products by the user for purposes determined solely by the user. No representations are intended or made as to the suitability of or engineering balance of or compliance with regulations or standard practice of any such combination of products or components the user may employ.

Abrasive blast equipment is only one component of an abrasive blasting job. Other products, such as air compressors, air filters and receivers, abrasives, scaffolding, hydraulic work platforms or booms, equipment for lighting, painting, ventilating, dehumidifying, parts handling, or specialized respirators or other equipment, even if offered by Clemco, may have been manufactured or supplied by others. The information Clemco provides is intended to support the products Clemco manufactures. Users must contact each manufacturer and supplier of products used in the blast job for warnings, information, training, and instruction relating to the proper and safe use of their equipment.

GENERAL INSTRUCTIONS

This material describes some, but not all, of the major requirements for safe and productive use of blast machines, remote controls, respirator systems, and related accessories. All equipment and accessories must be installed, tested, operated and maintained only by trained, knowledgeable, experienced users.

The blast operator and all workers in the vicinity must be properly protected from all job site hazards including those hazards generated by blasting.

Work environments involving abrasive blasting present numerous hazards. Hazards relate to the blast process from many sources that include, but are not limited to, dust generated by blasting or from material present on the surface being blasted. The hazards from toxic materials may include, but are not limited to, silica, cyanide, arsenic, or other toxins in the abrasives or in the coatings, such as lead or heavy metals. Other hazards from toxins include, but are not limited to, fumes from coating application, carbon monoxide from engine exhaust, contaminated water, chemicals or asbestos. In addition, physical hazards that may be present include, but are not limited to, uneven work surfaces, poor visibility, excessive noise, and electricity. Employers must identify all job site hazards and protect workers in accordance with OSHA regulations.

Never modify Clemco equipment or components or substitute parts from other manufacturers for any Clemco components or parts. Any unauthorized modification or substitution of supplied-air respirator parts violates OSHA regulations and voids the NIOSH approval.

IMPORTANT

Contact Clemco for free booklets:

Blast Off 2 – Guide to Safe, Productive, and Efficient Abrasive Blasting, and Abrasive Blasting Safety Practices – Guide to Safe Abrasive Blasting.

Clemco Industries Corp. One Cable Car Drive Washington MO 63090

Tel: 636 239-4300 — Fax: 800 726-7559

Email: info@clemcoindustries.com

Website: www.clemcoindustries.com

OPERATIONAL INSTRUCTIONS

OPERATOR SAFETY EQUIPMENT

WARNING

- OSHA regulation 1910.134 requires appropriate respiratory protection for blast operators and workers in the vicinity of blasting. These workers must wear properly-fitted, properly-maintained, NIOSH-approved, respiratory protection that is suitable for the job site hazards. Blast respirators are to be worn only in atmospheres not immediately dangerous to life or health from which wearers can escape without use of the respirator.
- The employer must develop and implement a written respiratory protection program with required worksite- specific procedures and elements for required respirator use. The employer must provide effective training to employees who are required to use respirators. The training must be comprehensive, understandable, and recur annually, and more often if necessary.
- NEVER use abrasives containing more than one percent crystalline silica. Fatal diseases, such as silicosis, asbestosis, lead or other poisoning, can result from inhalation of toxic dusts, which include, but are not limited to, crystalline silica, asbestos, and lead paint. Refer to NIOSH Alert 92-102; and OSHA CPL 03-00-007: “National Emphasis Program – Crystalline Silica”, in which OSHA describes policies and procedures for implementing a national emphasis program to identify and reduce or eliminate health hazards from exposure to crystalline silica. Numerous topics associated with the hazards of crystalline silica in silica blasting sand can be found on [http:// osha.gov/](http://osha.gov/). Clemco urges users of silica blasting sand to visit this website, and read and heed the information it contains.
- Always make sure the breathing air supply (respirator hose) is not connected to plant lines that supply gases that include, but are not limited to, oxygen, nitrogen, acetylene, or other non-breathable gas. Never modify or change respirator air line connections without first testing the content of the line for safe breathing air. Failure to test the line may result in death to the respirator user.

- Breathing air quality must be at least Grade D, as defined by the Compressed Gas Association specification G-7.1, per OSHA Regulation 29 CFR 1910.134. When compressed air is the breathing air source, a Clemco CPF (suitable sorbent bed filter) should be used. Respirator hose connecting the respirator to the filter must be NIOSH approved. Non- approved hose can cause illness from chemicals employed to manufacture the hose.

- All workers must always wear NIOSH-approved respirators when any dust is present. Exposure to dust can occur when handling or loading abrasive, blasting, cleaning up abrasive, or working in the vicinity of blasting. Before removing the respirator, test the air with a monitoring device to ensure it is safe to breathe.

- Clemco respirators DO NOT remove or protect against carbon monoxide or any other toxic gas. Monitoring devices must be used in conjunction with the respirator to ensure safe breathing air. Always locate compressors and ambient air pumps where contaminated air will not enter the air intake.

- Always use Clemco lenses with Clemco respirators; installing non-approved lenses voids the NIOSH approval. Respirator lenses are designed to protect the wearer from rebounding abrasive; they do not protect against flying objects, heavy high-speed materials, glare, liquids, or radiation.

INDUSTRY ORGANIZATIONS

For additional information, consult:

Occupational Safety and Health Administration (OSHA) - www.osha.gov

Compressed Gas Association (CGA) - www.cganet.com

The Society for Protective Coatings (SSPC) - www.sspc.org

National Association of Corrosion Engineers (NACE) - www.nace.org

American Society for Testing and Materials (ASTM) - www.astm.org

National Institute of Occupational Safety and Health (NIOSH) - www.niosh.gov

American National Standards Institute (ANSI) - www.ansi.org

PREFACE

BLAST MACHINES AND REMOTE CONTROLS

⚠ WARNING

OSHA regulation 1910.169 describes the necessity of pressure relief valves on compressed air equipment. Do not operate blast machines with air compressors that are not equipped with properly functioning pressure relief valves.

OSHA regulation 1910.244(b) requires the use of remote controls on blast machines.

Serious injury or death can result from many sources, among them:

- Involuntary activation of the remote controls. Never modify or substitute remote control parts; parts are not compatible among different manufacturers. Welding hose is not suitable for remote control hose. Its ID and material composition make it unsafe for remote control use.
- Exceeding the maximum working pressure. Clemco blast machines are built to ASME-code and carry a 'U' or 'UM' stamp, and National Board/serial number. Every machine is marked with its maximum working pressure. Never exceed the maximum working pressure limits of the blast machine.
- Uncontrolled blast stream. High-velocity abrasive particles will inflict serious injury. Always point the blast nozzle in the direction of the blast surface only. Keep unprotected workers out of the blast area.
- Welding on the blast machine. Never weld on the blast machine; welding voids the National Board approval and may affect the dimensional integrity of the vessel.
- Moving the blast machine. Never manually move a blast machine containing abrasive, any machine containing abrasive must be moved with appropriate mechanical lifting equipment.

HOSES, COUPLINGS, AND NOZZLE HOLDERS

- The inside diameter (ID) of air hoses, fittings, and connections should be at least four times larger than the nozzle orifice size. Blast hose ID should be three to four times the size of the nozzle orifice. Example: a #6 nozzle (3/8" diameter orifice) calls for 1-1/2" ID blast hose and 1-1/2" ID or larger compressor hose. All hose runs should be kept as short as possible and run in as straight a line as possible to reduce pressure loss.
- To install, squarely cut the end of the hose so that it fits snugly against the coupling or hose end shoulder. Always use the screws recommended by the manufacturer ensuring that they do not penetrate the inner wall. Make sure the couplings tightly fit the hose. Install cotter pins at every connection or use couplings with built-in lock-springs to prevent disengagement. Install safety cables at all connections to prevent whipping if hoses disengage or blow out.

MAINTENANCE AND REPAIR

- Completely read and follow all service instructions and recommended maintenance intervals. Always shut off compressor and depressurize blast machine before performing any maintenance. At every service interval, clean all filters, screens, and alarm systems. If spring-loaded abrasive valves are used, always cage spring before disassembly.

WARRANTY

The following is in lieu of all warranties, express, implied or statutory, and in no event shall seller or its agents, successors, nominees or assignees, or either, be liable for special or consequential damage arising out of a breach of warranty. This warranty does not apply to any damage or defect resulting from negligent or improper assembly or use of any item by the buyer or its agent or from alteration or attempted repair by any person other than an authorized agent of seller. All used, repaired, modified, or altered items are purchased "as is" and with all faults. In no event shall seller be liable for consequential or incidental damages. The sole and exclusive remedy of buyer for breach of warranty by seller shall be repair or replacement of defective parts or, at seller's option, refund of purchase price, as set forth below

1. Seller makes no warranty with respect to products used other than in accordance hereunder.
 2. On products seller manufactures, seller warrants that all products are to be free from defects in workmanship and materials for a period of one year from date of shipment to buyer, but no warranty is made that the products are fit for a particular purpose.
 3. On products which seller buys and resells pursuant to this order, seller warrants that the products shall carry the then standard warranties of the manufacturers thereof, a copy of which shall be made available to the customer upon request.
 4. The use of any sample or model in connection with this order is for illustrative purposes only and is not to be construed as a warranty that the product will conform to the sample or model.
 5. Seller makes no warranty that the products are delivered free of the rightful claim of any third party by way of patent infringement or the like.
 6. This warranty is conditioned upon seller's receipt within ten (10) days after buyer's discovery of a defect, of a written notice stating in what specific material respects the product failed to meet this warranty. If such notice is timely given, seller will, at its option, either modify the product or part to correct the defect, replace the product or part with complying products or parts, or refund the amount paid for the defective product, any one of which will constitute the sole liability of the seller and a full settlement of all claims. No allowance will be made for alterations or repairs made by other than those authorized by seller without prior written consent of seller. Buyer shall afford seller prompt and reasonable opportunity to inspect the products for which any claim is made as above stated.
- Except as expressly set forth above, all warranties, express, implied or statutory, including implied warranty of merchantability, are hereby disclaimed.

PREFACE

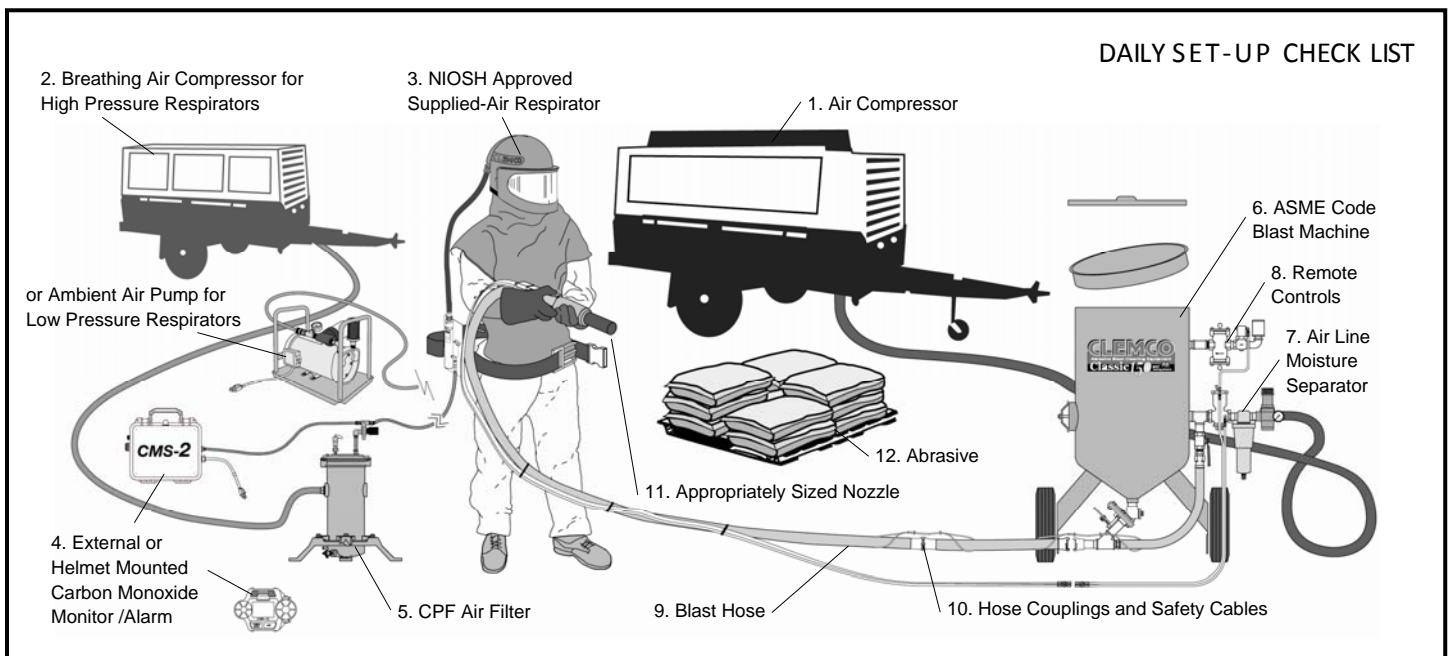

DAILY SET-UP CHECK LIST

Make sure all blast operators are properly trained and suitably attired with a blast suit, safety boots, leather gloves, respiratory and hearing protection. Every day before start up, check all equipment components, including piping, fittings, and hoses, and valves, for leaks, tightness, and wear. Repair or replace as needed. Use the following checklist.

- 1. PROPERLY-MAINTAINED AIR COMPRESSOR** sized to provide sufficient volume (cfm) at given pressure for nozzle and other tools. ADD 50% volume (cfm) reserve to allow for nozzle wear. Use large compressor outlet and air hose (at least 4 times the nozzle orifice diameter). For oil-lubricated compressors, the employer shall use a high- temperature or carbon monoxide alarm, or both, to monitor carbon monoxide levels. If only high-temperature alarms are used, the air supply shall be monitored at intervals sufficient to prevent carbon monoxide in the breathing air from exceeding 10 ppm. Follow the manufacturer's checklist and maintenance instructions.
- 2. BREATHING-AIR COMPRESSOR** (or oil-less ambient air pump) capable of providing Grade D quality air, located in a dust free area. Read # 1 above.
- 3. CLEAN, PROPERLY-MAINTAINED NIOSH-APPROVED SUPPLIED-AIR RESPIRATOR** worn by blast operators, and other workers exposed to blast dust. Make sure all respirator components are in place — all lenses, inner collar, and cape. Thoroughly inspect all components for wear. The NIOSH approval (approval number is listed in the owner's manual) is for a complete assembly from point of attachment on the CPF (sorbet bed) filter to the complete respirator. Substitution of any part voids the NIOSH approval.
- 4. CARBON MONOXIDE MONITOR/ALARM** installed at the CPF filter or inside the supplied-air respirator for monitoring for the presence of deadly CO gas and warning the operator(s) when the CO level reaches an unacceptable level. When an ambient air pump is used for breathing air, a CO monitor provides a measure of safety. Read # 1 above.
- 5. BREATHING-AIR FILTER (OSHA-REQUIRED sorbet bed filter)** for removal of moisture and particulate matter in the compressed air breathing-air supply. Monitor the condition of the cartridge and replace when odor is detected or at 3 month intervals, whichever comes sooner. The breathing air filter does NOT detect or remove carbon monoxide (CO). Always install a CO monitor/alarm.
- 6. BLAST MACHINE** (bearing U or UM stamp, National Board Number, and Maximum Working Pressure) sized to hold a 30-minute abrasive supply. Examine pop-up valve for alignment. Check piping, fittings, screens, valves for tightness, leaks, and wear. Always ground the machine to eliminate hazard of static shock. Install a blast machine screen to keep out foreign objects. Use a blast machine cover if left outdoors overnight. Never exceed the maximum working pressure of the vessel.
- 7. AIR LINE FILTER** (moisture separator) installed as close as possible to the blast machine inlet and sized to match the size of the inlet piping or larger air supply line. Clean filter and drain often. Damp abrasive causes operational problems.
- 8. REMOTE CONTROLS** are required by OSHA and must be in perfect operating condition. Test and check all components to ensure all parts are present and fully functional. Use genuine replacement parts. NEVER mix parts from different manufacturers. Never use welding hose for remote control hose.
- 9. BLAST HOSE** should have an inside diameter sized to suit the blast nozzle. The ID should be three to four times the size of the nozzle orifice diameter. Blast hose should be arranged in as straight a line as possible from the blast machine to the work area, avoiding sharp bends.
- 10. COUPLINGS AND NOZZLE HOLDERS** should fit snugly on the hose and be installed with manufacturer recommended screws. Coupling lugs must snap firmly into locking position. Gasket must always be used to form a positive seal, and cotter pins must be installed. Replace gasket when wear, softness or distortion is detected. Check nozzle holder for thread wear; replace at any sign of wear. Install safety cables at all connections.
- 11. NOZZLE** orifice size should be checked and nozzle replaced when worn 1/16" from original size. (No. 5 nozzle has 5/16" orifice diameter; replace when it measures 3/8"). Threads should be inspected daily for wear and nozzle should be replaced when wear is detected. Always use a nozzle washer.
- 12. ABRASIVE** must be a material specifically manufactured for blasting. It should be properly sized for the job. Check material safety data sheet for free-silica, cyanide, arsenic, lead and other toxins and avoid use when these toxic, harmful substances are present.
- SURFACE TO BE BLASTED** should be examined for hazardous substances. Take appropriate protective measures as required by OSHA to ensure the blast operator, other workers in the vicinity, and any bystanders are properly protected.

1.0 INTRODUCTION

1.1 Scope of manual

1.1.1 These instructions cover set-up, operation, maintenance, troubleshooting, and replacement parts for the CMS-2 contractor series carbon monoxide (CO) monitor.

1.1.2 The CMS-2 monitor is manufactured by Invertech Inc. for Clemco Industries Corp. The monitor is a potential life saving instrument. To assure its performance, the monitor must be properly installed, tested, calibrated, and maintained. Before installing and using the monitor, all personnel involved with the operation and maintenance of the instrument must read this entire manual, including the orange cover.

1.2 Safety Alerts

1.2.1 Clemco uses safety alert signal words, based on ANSI Z535.4-2011, to alert the user of a potentially hazardous situation that may be encountered while operating this equipment. ANSI's definitions of the signal words are as follows:



This is the safety alert symbol. It is used to alert you to potential physical injury hazards. Obey all safety messages that follow this symbol to avoid possible injury or death.

NOTICE

Notice indicates information that is considered important, but not hazard-related, if not avoided, could result in property damage.

CAUTION

Caution indicates a hazardous situation that, if not avoided, could result in minor or moderate injury.

WARNING

Warning indicates a hazardous situation that, if not avoided, could result in death or serious injury.

DANGER

Danger indicates a hazardous situation that, if not avoided, will result in death or serious injury.

1.3 Components

1.3.1 The primary components of the monitor are shown in Figure 1. The instrumentation is enclosed in a corrosion resistant polypropylene carrying case. The monitor system includes the instrument case, ten feet of 1/8" ID x 1/4" OD tubing with fittings, a cylinder of 10 PPM (parts per million) test gas, calibration connector which includes the connector valve, tubing and humidifier.

1.4 Operating Principles

1.4.1 The CMS monitor samples respiratory air from a breathing-air source. This enables one monitor to detect CO and other toxic gases in the entire breathing air system, not just for one respirator. The air to the respirator does not actually pass through the monitor.

WARNING

When the CMS is correctly installed and maintained, it monitors the level of carbon monoxide and other oxidizable toxic gases in the air supply. The instrument is a monitoring device; it DOES NOT remove or convert carbon monoxide or any other toxic gases.

1.4.2 During operation, a small sample of air, referred to as "sample-air", passes through the instrument, and is continuously monitored by the broadband MOS (Metal Oxide Substrate) sensor. Although the sensor detects CO (carbon monoxide), it also detects other oxidizable toxic gases (hydrocarbons). If the "sample-air" supply fails for any reason such as air blockage, loss of pressure, or excessively high pressure, an intermittent audible alarm will sound and the exterior alarm light will illuminate "yellow" to alert the user.

1.4.3 In the event the sensor detects CO in the concentration of 10 PPM (parts per million) or above, a continuous audible alarm will sound and the exterior alarm light will illuminate "red" to alert the user.

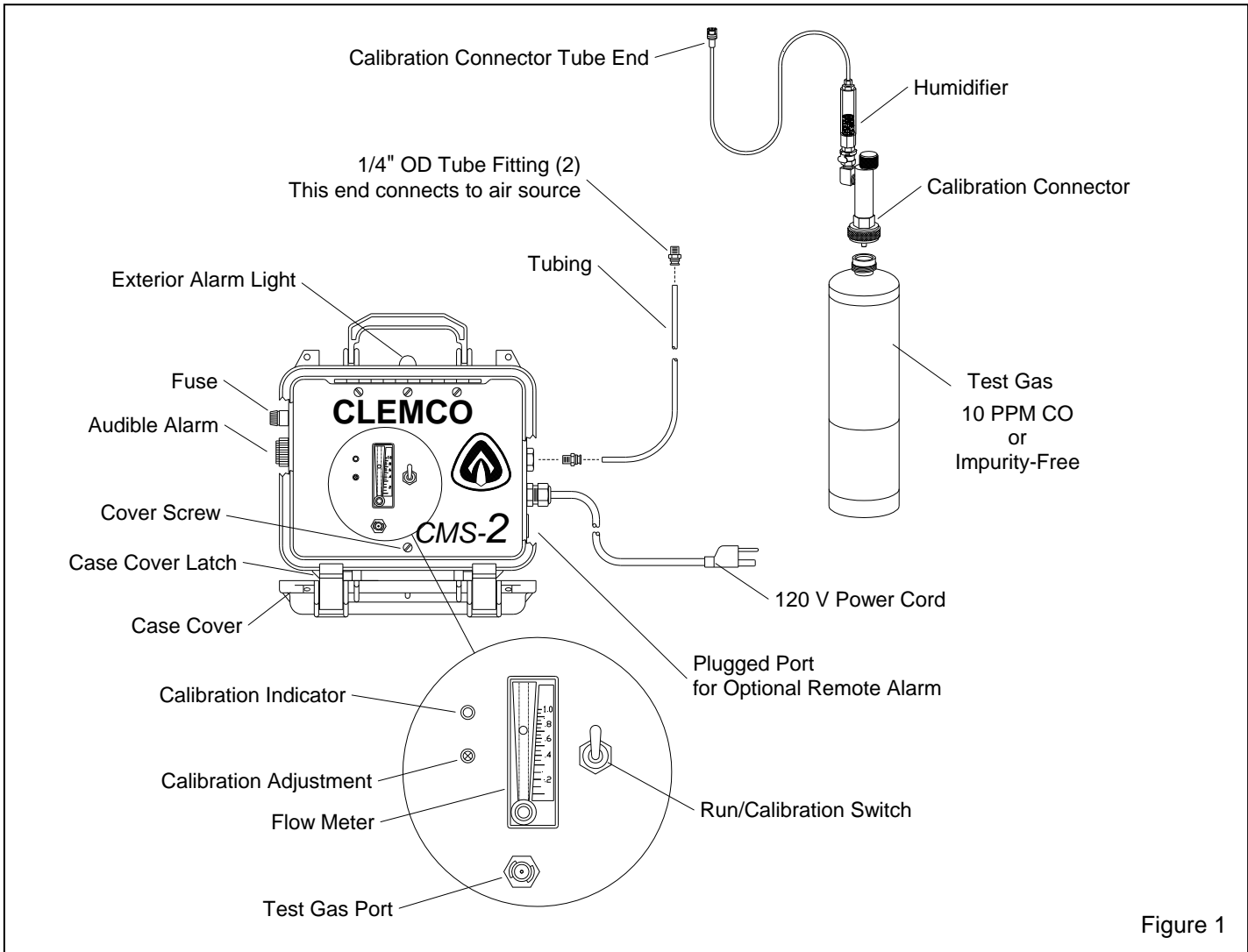

Figure 1

1.5 Annunciator Lights and Audible Alarms and Switches

1.5.1 Audible and visual alarms are provided on the exterior of the instrument case and on the interior faceplate. The exterior light illuminates "green" when conditions are safe, or "yellow" or "red", depending on the alarm condition. The audible alarm sounds in conjunction with the visual alarm.

1.5.2 The color of the alarm light in conjunction with the nature of the audible alarm indicates the condition causing an alarm. Functions of the alarm annunciators are as follows:

1.5.3 Interior Calibration Light

Red Light - Intermittent Audible Alarm

- The interior alarm light (calibration indicator), on the faceplate of the instrument, responds to toxic gas conditions only. It is for use by the technician during calibration testing, and for calibration when the instrument case is open.

1.5.4 Exterior Alarm Annunciators

Green Light - No Audible Alarm

- No Alarm, Safe Condition: Do not use the compressed air for breathing unless the exterior light is illuminated "green".

⚠ WARNING

All alarm conditions require the immediate attention of the user. Stop blasting immediately, and remove the respirator as soon as it is safe to do so, and check the monitor to determine the cause for alarm.

Yellow Light - Intermittent Audible Alarm

Sample-Air Failure: This alerts the user that pressure in the test chamber is either too low or too high. Low pressure is usually due to loss of pressure in the sample-air air line. High pressure is an indication that the internal regulator is set too high. Correct flow is observed on the flow meter; the flow ball is usually between .5 and .8 SCFH.

- Calibration in process: During calibration testing and the calibration procedure, this alarm is activated. The alarm will terminate when the technician has correctly returned the monitor to service.

Yellow Light - No Audible Alarm

- Warm-Up Period: During the first several minutes of operation, the monitor goes through a warm-up period while the sensor stabilizes. During the warm-up period, the yellow light illuminates, and all other alarms are non operational. The alarm will terminate after the warm-up is complete.

Red Light - Continuous Audible Alarm

- Toxic Gas Detected: This alarm occurs when toxic gas or CO in excess of 10 PPM is detected in the breathing air line.

1.5.5 Run/Calibration Switch: The toggle should be in the "RUN" position for all operations other than the actual calibration test and calibration process. If, for any reason, the toggle is not in the "RUN" position, the instrument will initiate a "yellow" light and intermittent alarm, indicating that the sample-air is not reaching the sensor. Correctly positioning the toggle will terminate the intermittent alarm.

1.6 Optional Accessories

1.6.1 Remote Alarm: The 12-volt DC remote alarm is a high-intensity, red lens strobe light and high decibel horn. Unlike external alarms, this alarm does not require an external power source. This accessory is recommended in high noise areas, or where the monitor cannot be placed in a conspicuous location. The alarm kit includes the alarm, stand, wiring connector, and 50 ft. cable. See Accessories in Section 8.1. With additional cable, the alarm may be used up to 150 ft. from the monitor. Consult Clemco Industries Corp. if longer length is required.

1.6.2 Air Line Humidifier: This accessory is used to humidify sample-air when the instrument is used to monitor air lines where the air has been dried to 30% RH (relative humidity) or less.

2.0 SET-UP**2.1 Compressed Air Requirements**

2.1.1 Air Pressure: If the compressed air source pressure is between 55 psi and 120 psi, no pressure adjustment is required. If line pressure is above 120 psi, a regulator is required to reduce pressure to be within the 55 to 120 psi operating range.

2.1.2 Air Connection**NOTICE**

Do not use pipe joint compound to seal pipe fittings. The monitor will respond to the gases given off by these compounds. Use Teflon tape for pipe thread sealer.

Do not use any silicone-based lubricants upstream of this instrument. Silicone exposure will prematurely damage the sensor.

2.1.2.1 If the instrument is used to monitor air lines where the air has been dried to 30% RH or less, mount an optional humidifier in an upright position between the air supply source and monitor inlet.

2.1.2.2 To ensure accurate and rapid air monitoring, the monitor must be placed as close to the compressed air source as practical. Ten feet of 1/8" ID tubing with two 1/4" NPT fittings are furnished, to be used between the compressed air source and monitor inlet. Larger diameter tubing or pipe, or longer tubing, increases the air supply volume, and the volume determines the length of time it takes for the sample-air to reach the monitor.

2.1.2.3 Determine a suitable place to tap into the compressed air supply. The tap location should be within 10 feet of the monitor, and the monitor must be placed in a location that permits continual observance of the visual and audible alarms.

⚠ WARNING

The monitor or an auxiliary alarm must be in a conspicuous place to ensure that any alarm condition is observed. Using the auxiliary terminals and a relay, the monitor may be interlocked with other devices such as the compressor shut-down, as an additional safeguard against an unobserved alarm.

2.1.2.4 Place a tee in the air supply line, and use a bushing or other adaptor, to connect one of the 1/4" NPT tube fittings supplied. Install an isolation valve at the

source to enable depressurization for service and to remove the monitor. Typical set-ups are shown in Figure 2.

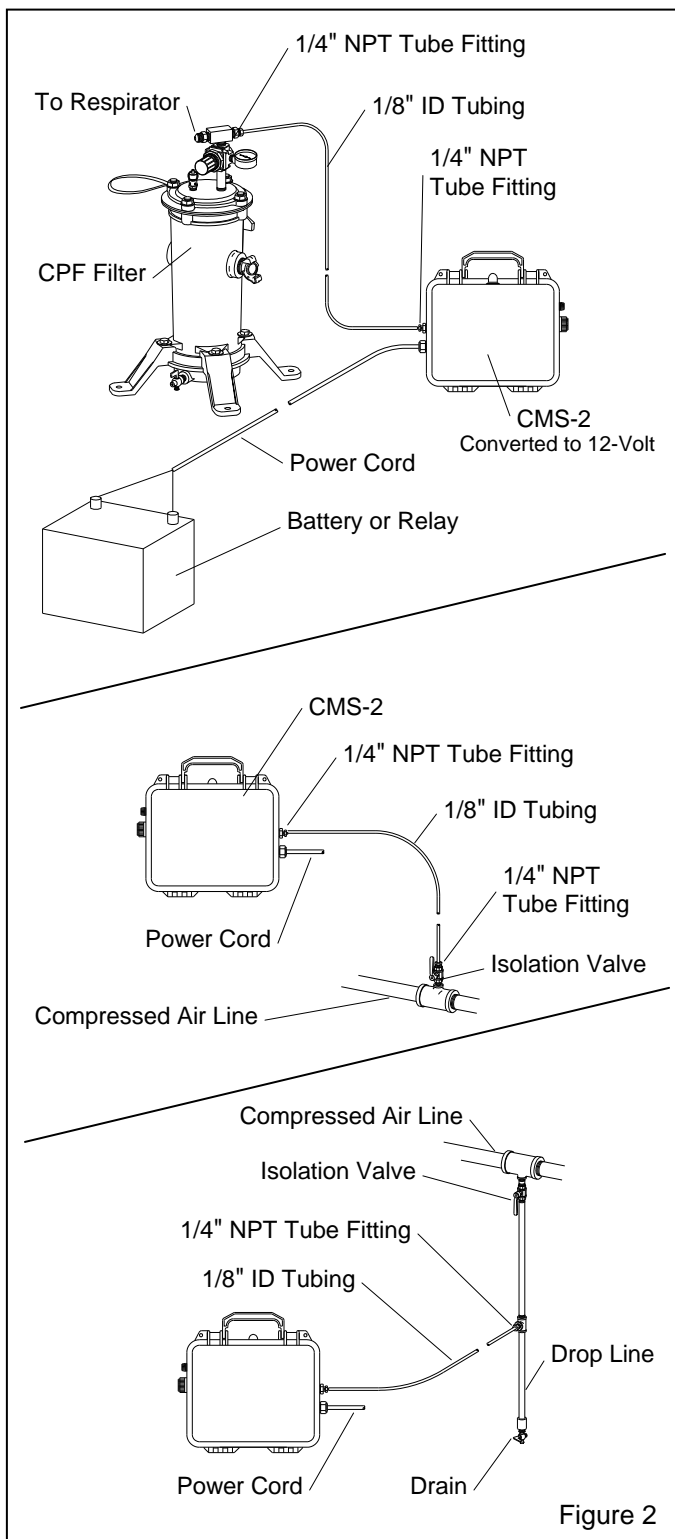

Figure 2

2.1.2.5 The tee in the air supply line should face up to prevent water from accumulating in the sample-air line. If the tap cannot face upward, install a drop pipe and drain to prevent water from entering the monitor.

2.1.2.6 Connect the other 1/4" NPT tube fitting to the monitor's inlet port.

2.1.2.7 Attach the urethane tubing between the air supply tube fitting and monitor inlet tube fitting. Remove excess tubing.

2.2 Electrical Requirements

2.2.1 120 / 220 Volt AC: The only difference between the 120 VAC and 220 VAC monitors is the power cord. Monitors are supplied with a 120-volt AC power cord or 220-volt AC power cord, and can be plugged into a compatible, grounded electrical source.

2.2.2 12-Volt DC: A DC monitor model is available from the Clemco, or an AC monitor is easily field-converted to operate on 12-volt DC, as noted in Section 2.3.

2.3 AC to DC Field Conversion, Serial No. 4446 and greater.

To convert monitors with serial numbers lower than 4446, request Manual No. 22925, Revision E or earlier.

The AC power cord provided with the monitor may be used, using "black" as the positive. A user supplied DC 2-wire cord may be used, using "red" as positive. If a new 12-volt cord is used, splice the positive through the fuse, and use the spade on the outlet of the fuse to connect to the positive terminal, as shown Figure 3.

2.3.1 Make sure that all electrical power to the monitor is disconnected.

2.3.2 Open the case to access the interior faceplate.

2.3.3 Loosen the cover screw located in the center of the lower edge of the faceplate. Refer to Figure 1.

2.3.4 Swing the faceplate up to access the instrumentation.

2.3.5 Remove the connector with red and black wires from the plug on the circuit board, as shown in Figure 3. If there is a chance the monitor will be converted back to AC power, tie the wires out of the way. If the monitor is to be permanently converted to 12-volts, pop off the clear terminal cover and remove the wires from the terminal.

2.3.6 Disconnect the "white" and "black" wires from the power supply lead wires at the connectors, as shown in Figure 3.

2.3.7 Plug the "black" wire onto the "DC+" post at the lower left corner of the circuit board, as shown in Figure 3.

Note the board is upside down when the cover is open. Plug the "white" wire onto the "DC-" post.

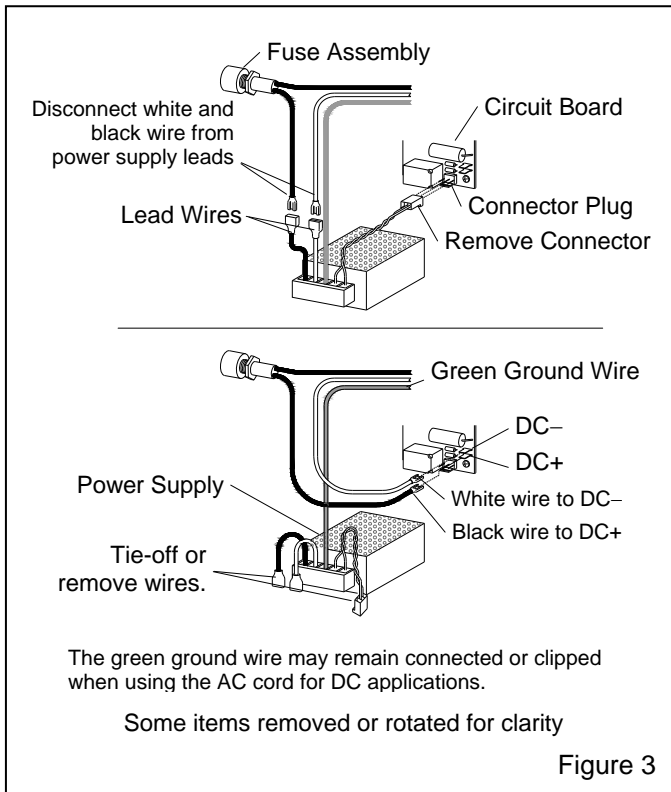

Figure 3

- 2.3.8 Remove the plug from the other end of the cord.
- 2.3.9 When closing the faceplate, make sure that all internal air lines are free of interference, binding or kinks and that all tube connections are secure. Tighten the cover screw.
- 2.3.10 Close and latch the instrument case cover.
- 2.3.11 Attach a positive (+) terminal connector to the end of the "black" wire and a negative (-) connector to the end of the "white" wire. Clip the green wire.

NOTICE

Use any connectors that are compatible with a 12-volt DC system. Make sure the connectors are clearly marked positive (+) and negative (-). Attach the positive connector to the wire leading to the "DC+" post on the circuit board, and the negative connector to the "DC-" post on the circuit board. The monitor will not operate if wires are reversed.

2.4 External Alarm and Shut-Down Device. Refer to Figure 4. Note: External alarms require external

power. Do not confuse an external alarm with the optional remote alarm, which does not require external power.

2.4.1 A dry relay contact is mounted on the circuit board (Ref. Figure 4), for use with external alarms and shut-down devices. These contacts are rated at 5 amperes. Use the contacts to operate relays for external devices.

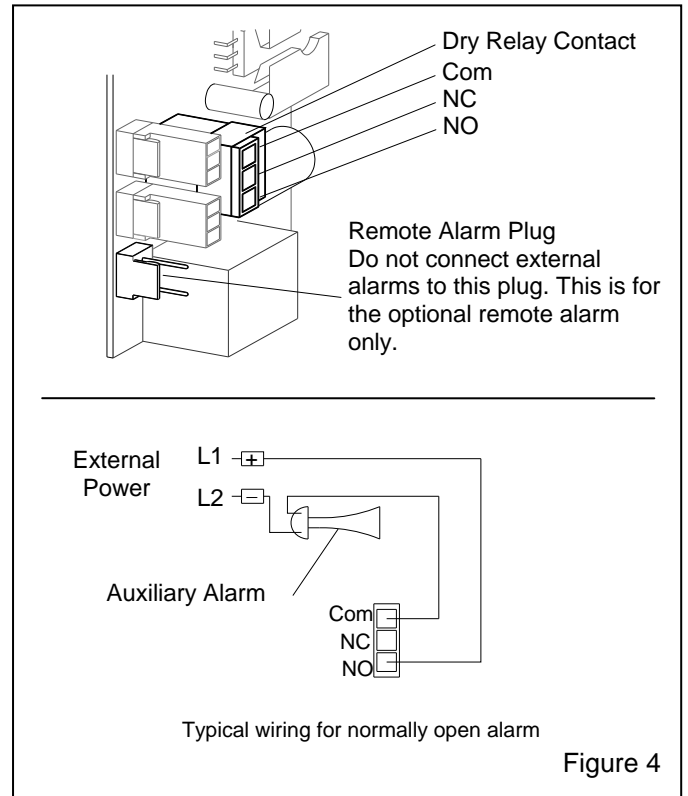

Figure 4

2.5 Mounting

2.5.1 The CMS-2 does not require any special mounting, and it will operate in any position. The carrying case handle may be used to hang the monitor in a convenient location that is close to the compressed air source. See Section 2.1.2.

⚠ WARNING

DO NOT mount this instrument inside a blast room. An operator inside a blast room wearing protective clothing may not observe an alarm condition. The alarm case is not designed to withstand the continual impact of abrasive that takes place inside a blast room. Refer to instructions within the manual for installing auxiliary horns, lights, and safety shut-down devices.

3.0 OPERATION

WARNING

Do not breathe compressed air that this instrument monitors unless the instrument has been calibration-tested, and if needed calibrated per Section 4.0. Using a monitor that has not been calibration-tested could permit undetected CO to enter the respirator air lines. Breathing toxic gases could cause death.

3.1 Set-Up for Operation

3.1.1 Position the Run/Calibration toggle switch to the "RUN" position.

3.1.2 Open the sample-air isolation valve to supply test air to the monitor.

3.1.3 Plug the instrument into a grounded 120-volt AC power supply. If the monitor is converted to operate on 12-volt power, connect to a 12-volt DC power source, being certain the positive and negative leads go to the correct terminal. There is no on/off switch on the monitor; it will initiate operation as soon as power is applied.

3.2 Warm-Up Period

3.2.1 With electrical power applied and 55 to 120 psi sample-air supplied to the inlet, the monitor will go through a five minute warm-up period.

3.2.2 During the warm-up period, the audible alarms are disabled and the external visual alarm is "yellow". At the end of the warm-up period, the "yellow" exterior light turns "green", indicating that the instrument is functioning and the sample-air does not exceed the contamination limit.

NOTE: If the instrument has been off for a prolonged period, it is normal for the alarms to activate for a short period of time after the warm up cycle.

3.2.3 Ensure alarms function per Section 5.5. If the alarms function as described, proceed to place the instrument in operating mode, per Section 3.3.

3.2.4 If the instrument goes into an alarm (exterior light remains "red" with continuous audible alarm) after the warm-up, re-initiate warm-up by terminating and restarting power.

3.2.5 Continued alarm condition after several warm-up periods indicates that the sample-air exceeds the

permissible contamination level, or the instrument requires calibration. Refer to Section 4.0.

WARNING

DO NOT use the respirator during the warm-up period. The alarms are disabled and will not warn against toxic gases.

3.3 Operating Mode

3.3.1 Following the warm-up period, with the toggle correctly positioned to "RUN", and the sample-air flowing through the unit, the monitor is in full operating mode.

3.3.2 Before donning the respirator, verify that the monitor is in the operating mode; The exterior alarm light must be "green", with no audible alarm.

WARNING

Do not use compressed air monitored by this instrument for breathing without first checking to make sure the instrument is in full operating mode, and the exterior alarm light is illuminated "green". Failure to heed this warning could cause death from the inhalation of carbon monoxide.

3.4 Shut-down

3.4.1 If the instrument is not to be moved, and is protected from the weather, simply shut off the isolation valve, and unplug the power cord. If the unit is to be transported, or if it is not protected from the weather, proceed as follows:

3.4.2 Watch the flow meter; when air flow stops, remove the urethane tubing from the supply line and monitor inlet. The tubing is easily removed by pushing in the tube fitting ring while pulling the tubing.

3.4.3 Coil the tubing and place it inside the instrument case to keep the tubing clean.

3.4.4 Place tape or other cover over the inlet fitting to keep instrumentation clean.

3.4.5 Transport the instrument in the passenger compartment of the service vehicle, not in the trunk or truck bed. See "Care and Handling" in Section 5.1.

4.0 CALIBRATION TEST and CALIBRATION

Note: Thoroughly review and understand the calibration testing and the calibration process before testing or calibrating the instrument. Refer to Section 4.1.

⚠ WARNING

This instrument must be tested and calibrated with 10 PPM test gas. Do not test or calibrate with any other test gas concentration. Doing so will place the monitor out of calibration, and may fail to alert the user of toxic gases. Breathing toxic gases could cause death.

4.1 Testing and Calibration

4.1.1 It is important to understand the difference between the calibration testing and the calibration process.

4.1.2 Calibration testing: Calibration testing means applying test gas of a known concentration to the instrument to ensure that it responds with an alarm when CO concentrations exceed the permissible level, and that it responds with a safe signal when impurity-free air is applied. Calibration testing does not include any adjustment of the instrument. Calibration (adjustments) should be done only when calibration testing shows it is necessary.

4.1.3 Calibration: Calibration means adjusting the instrument. Calibration should be done only when the instrument does not respond during calibration testing, or remains in alarm at start-up.

4.2 Materials Required for Tests and Calibration

- 10 PPM test gas.....Stock No. 22865
- Impurity-free test gasStock No. 11132
- (when required, see Section 4.9)
- Calibration connector.....Stock No. 22893
- Distilled water
- Small adjusting screwdriver
(when calibration is required)

4.3 Stabilization

4.3.1 The monitor must be in operation for at least 30 minutes before calibration testing. DO NOT test the instrument until it has gone through the warm-up period and has been in operation with sample-air flowing through it (See Section 3.0) for at least 30 minutes.

4.4 Prepare Calibration Connector

NOTE: Unlike ambient air, calibration test gas is bone-dry. Attempts to test or calibrate the monitor without humidifying the test gas will cause significant reading errors of compressed air with normal levels of humidity.

4.4.1 Before connecting the calibration connector to the test gas, dampen the humidifier media with distilled water as follows: Ref. Figure 5.

4.4.2 Press and hold the release button and the pull the humidifier assembly out of the release connector body.

4.4.3 Turn the humidifier upside down, and moisten the sponge by putting a few drops of distilled water into the connector, as shown in Figure 5.

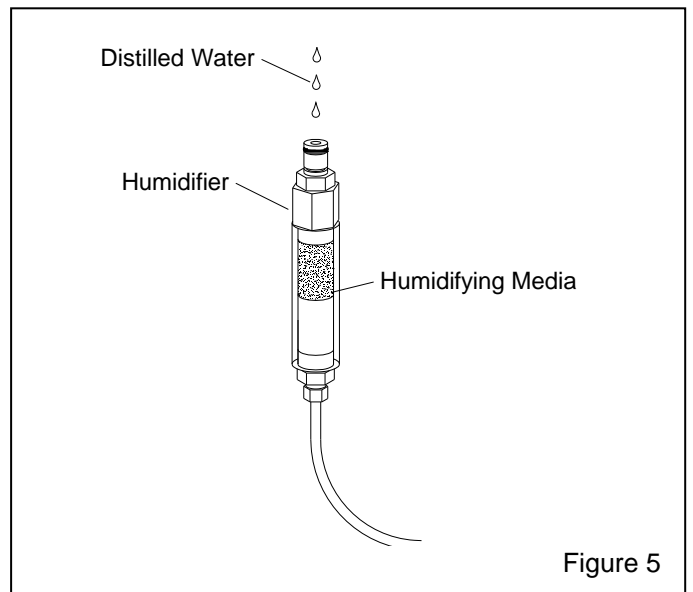

Figure 5

4.4.4 Hold the tubing end of the connector and shake out excess water. **NOTE: The humidifier needs to be dampened only; excess water must be removed so that it does not enter the instrument plumbing.**

4.4.5 Reconnect the humidifier to the connector by pushing the humidifier into the release body. Gently pull the connector to make sure it is correctly seated in the body.

4.4.6 Make sure the flow-control knob is turned fully clockwise to the "OFF" position. Refer to Figure 6.

4.4.7 Attach the test gas connector to the cylinder of calibration gas (Use 10 PPM CO test gas to check the calibration or to calibrate the monitor. Use zero, impurity-free, air to check if alarm is due to contaminated air or other condition).

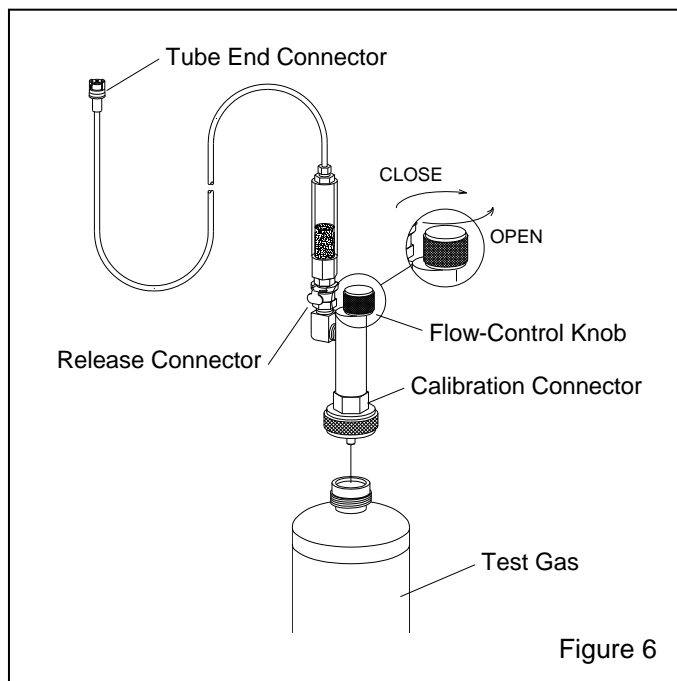

Figure 6

4.5 Prepare Instrument

4.5.1 Open the instrument case cover to access the interior faceplate. Take care not to introduce blast environment contaminants into the instrument when the case is open. See Figure 7 for faceplate-calibration testing and calibration callouts.

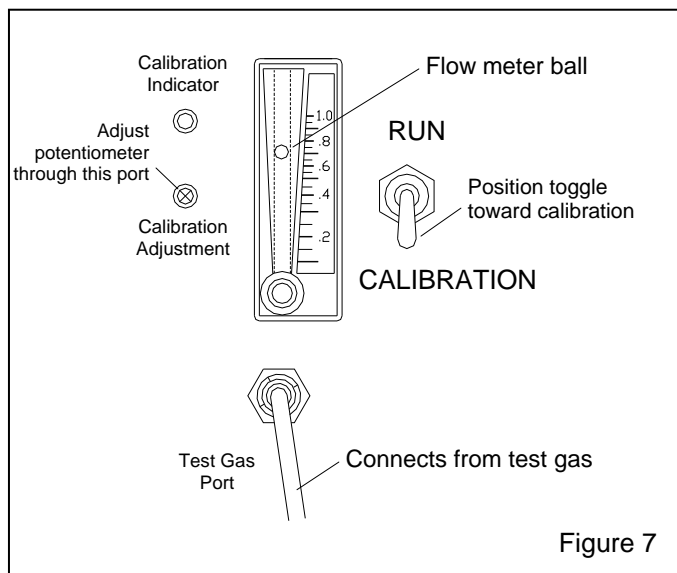

Figure 7

4.5.2 Connect the calibration connector to the "Test Gas Port" by aligning the tabs and inserting the tube end connector into the port, and turning it slightly clockwise until it locks.

4.5.3 Place the Run/Calibration toggle toward "CALIBRATION". The external alarm light will

immediately turn "yellow", and within a few seconds the intermittent audible alarm will sound (the calibration indicator remains "green").

4.6 Calibration Testing

4.6.1 With the flow meter vertical, slowly open the flow-control knob to introduce test gas. Test gas is entering the unit when the flow meter ball rises. If the ball does not rise when the calibration valve is opened, the test gas cylinder is probably empty.

4.6.2 Adjust the flow-control knob until the flow meter ball remains between .5 and .8 SCFH. The valve is extremely sensitive. Minor adjustments may be required to correctly position the ball.

4.6.3 Allow test gas to flow through the instrument for about one minute, or until the interior calibration indicator light turns "red".

4.6.4 After the calibration light turns "red", the initial phase of the calibration test is complete. Return the instrument to operating mode per Section 4.8. If the indicator light does not turn "red" proceed with Paragraph 4.6.5.

4.6.5 If after one minute of operation with test gas the calibration indicator light has not turned "red", and the instrument has been in operation for 30 minutes, calibrate the instrument per Section 4.7. If the instrument has not been in operation for 30 minutes, return it to operating mode per Section 4.8, and operate with sample air flowing through for at least 30 additional minutes. Re-test the calibration, and if the calibration light does not turn "red", calibrate the instrument per section 4.7.

4.7 Calibration

4.7.1 Do not calibrate the instrument unless it has gone through two stabilizing periods and calibration tests, per Sections 4.3 and 4.6, and only if the calibration indicator light has not turned "red".

4.7.2 Prepare the calibration connector per Section 4.4 and attach it to a cylinder of 10 PPM CO test gas.

4.7.3 Connect the calibration connector to the "Test Gas Port" on the faceplate.

4.7.4 Place the Run/Calibration toggle toward "CALIBRATION". Slowly open the flow-control knob and adjust the flow so the flow ball remains between .5 and .8 SCFH.

4.7.5 Allow test gas to flow through the instrument for about one minute. Insert a small screwdriver into the calibration adjustment port, and turn the potentiometer as follows:

- If the potentiometer is **BLUE**, turn **clockwise** until the calibration indicator light turns "red".
- If the potentiometer is **"WHITE"**, turn **counterclockwise** until the calibration indicator light turns "red".

4.7.6 Once the indicator is "red", turn the potentiometer in the opposite direction until the light turns "green". Then, slowly turn the potentiometer from "green" to "red" several times to find the trip point. The monitor is calibrated at the spot where the light turns "red". Return the instrument to operating mode per Section 4.8.

4.8 Return to Operating Mode

4.8.1 Push the connector's slide valve to the "CLOSE" position.

4.8.2 To remove the calibration connector from the monitor, grip the tube end connector, turning it slightly counterclockwise to unlock, and pull straight out.

4.8.3 Place the calibration toggle switch to the "RUN" position. The flow meter ball should rise to .5 to .8 SCFH. After several seconds the external alarm light should change from "yellow" to "green", and the interior light should change to "green". If the lights respond as described, proceed with 4.8.4 to return the instrument to operation. If after about one minute of operation, the lights do not change to "green", do both of the following:

- Calibrate the instrument per Section 4.7.
- Test instrument function by applying impurity-free air, per Section 4.9.

4.8.4 Close and latch the instrument case cover.

4.8.5 Remove the calibration connector from the test gas cylinder. The test gas cylinder has a positive seal, whereas the calibration connector valve does not. If the connector is not removed from the test gas cylinder, over a period of time the cylinder will empty.

4.8.6 Store all material in a clean, dry area.

4.9 Impurity-Free Air (zero contamination) Test

4.9.1 This test should be done whenever the instrument stays in an alarm condition after it is returned to the operating mode. This test shows whether the

alarm condition is due to contaminated air, or monitor malfunction.

4.9.2 Follow the steps in Section 4.6 "Calibration Testing", except use impurity-free test gas in place of the 10 PPM gas. The alarm light will either remain "red" or turn "green". Proceed as follows:

4.9.3 Alarm light turns "green"

4.9.3.1 If the monitor is correctly calibrated and in working order, the alarm light will turn "green" during this test. This means the monitor was reading contaminated air. **DO NOT USE THE COMPRESSED AIR FOR BREATHING.**

WARNING

Do not breathe air that this instrument identifies as toxic, until the source of contamination is identified and corrected. Breathing toxic gases could cause death.

4.9.3.2 Identify the source of contamination. Do not overlook the possibility that contaminated air entered the compressor intake. The contamination could be from engine or other exhaust entering the intake. If the source of contamination is temporary, the monitor will return to a non-alarm (safe) condition after the contamination is cleared from the compressed air system.

4.9.4 Alarm light remains "red"

4.9.4.1 If the monitor is out of calibration or not in good working order, the alarm light will remain "red".

4.9.4.2 Calibrate the monitor per Section 4.7 and apply impurity-free gas per Section 4.9. If the alarm light remains "red", the monitor requires service. Refer Section 6.0.

WARNING

Do not use compressed air monitored by this instrument for breathing unless the instrument is in good working condition. Using a monitor that is not in calibration or not working correctly could permit undetected CO to enter the breathing-air lines. Breathing toxic gases could cause death.

5.0 GENERAL MAINTENANCE

5.1 Care and handling

5.1.1 This monitor is designed for portable, field use and is not adversely affected by normal handling that is required of any test and measurement instrument.

5.1.2 Transport the instrument in the passenger compartment of the service vehicle, do not transport in the trunk or truck bed.

NOTICE

Do not subject this instrument to extreme heat or cold. Placing the instrument case on the dashboard of the service vehicle in direct sunlight or similar condition will elevate the temperature inside the case to a level that will damage the instrument's electronic components. Avoid leaving or storing the monitor in freezing conditions. Freezing temperature will damage the instruments components.

5.2 Cleaning

5.2.1 The need to open the case periodically to calibrate the instrument exposes it to potential external contamination. Take care not to introduce contaminants into the instrument when the case is open.

5.2.2 Clean the exterior of the case with a solution of water and mild detergent. Do not use solvent cleaners.

5.3 Calibration Testing Schedule

5.3.1 Test the calibration when it is initially set-up, and again the day after. Check it once a week for the first month. Check it at least once a month thereafter. Refer to Section 4.0 for test procedure.

5.4 Calibration Schedule

5.4.1 Avoid the urge to calibrate the instrument. Calibrate only when the calibration test show it is required. See Section 4.0.

5.5 Alarm Tests

5.5.1 Although uncommon, alarm lights and horns do fail. Check their function before each use by placing the Run/Calibration toggle toward "CALIBRATION". The external alarm light will immediately turn "yellow", and within a few seconds the intermittent audible alarm will sound. Placing the toggle in "RUN" position returns the alarms to their normal operation. **Never use the**

respirator without first verifying that the monitor is in the operating mode; the exterior alarm light must be "green", with no audible alarm.

6.0 SERVICE MAINTENANCE

NOTE: Do not attempt to repair the instrument or replace any item that is not listed in this section, or that requires parts not listed in Section 8.2. Contact a Clemco distributor for authorization to return the instrument for evaluation or service.

6.1 Sensor Replacement

6.1.1 Sensor life depends upon several factors, but in most cases the sensor should last two to three years.

6.1.2 The following materials are required before replacing the sensor:

- 10 PPM test gas.....Stock No. 22865
- Calibration connector.....Stock No. 22893
- Sensor.....Stock No. 22919
- Standard screwdriver

6.1.3 Open the instrument case to access the interior faceplate. Take care not to introduce contaminants into the instrument when the case is open.

6.1.4 Loosen the closing screw located in the center of the lower edge of the faceplate.

6.1.5 Using the top hinge as the pivot, swing the faceplate up to expose the instrumentation.

6.1.6 Locate the clear-plastic sensor housing, shown in Figure 8, and while supporting the circuit board, loosen the two mounting screws.

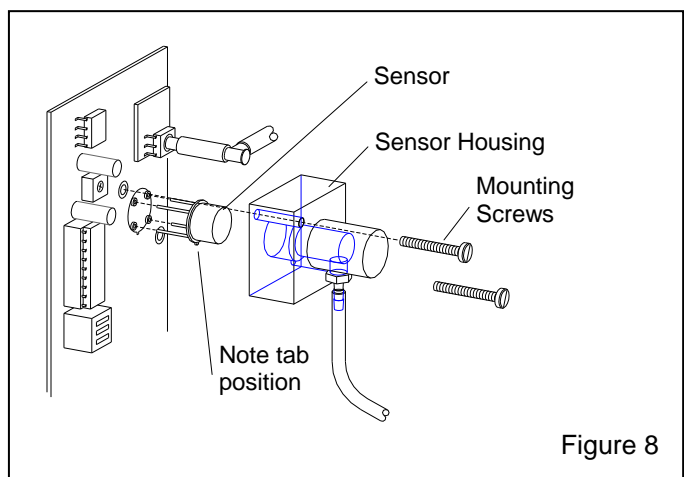

Figure 8

6.1.7 Carefully pull straight up to lift the sensor housing off the circuit board. The sensor may come off with the housing or stay plugged into the board.

6.1.8 If the sensor remains on the circuit board, note the location of the small tab, as the new sensor must be installed in the same orientation. While supporting the circuit board, carefully pull straight up to remove the sensor.

6.1.9 If the sensor comes off with the housing, note the tab location, and remove the sensor by pulling on a couple of the sensor pins.

6.1.10 Discard the old sensor to avoid attempts to reuse.

6.1.11 Handle the new sensor taking care not to distort the pins. Rotate the sensor so the tab is in the same position as was the old one (as shown in Figure 8) and plug the pins into the socket. Some pin alignment may be required, and is normal. Push firmly but carefully to seat the sensor. The sensor will stand off the circuit board by approximately 1/4" when seated.

6.1.12 Place the sensor housing over the sensor, align the mounting screw holes, and while supporting the circuit board, tighten the screws snugly. **Do not over-tighten the screws.**

6.1.13 When closing the faceplate, make sure that all internal air lines are free of interference, binding or kinks, and that all tube connections are secure. Tighten the closing screw.

6.1.14 Close the instrument case and apply sample air and power per section 3.0, and allow the monitor to run in operating mode for at least one hour.

6.1.15 Calibrate the monitor per Section 4.0.

6.1.16 Return the monitor to service and record sensor replacement date.

6.1.17 Follow the calibration testing schedule per Section 5.3.

6.2 Fuse Replacement

6.2.1 The fuse cap is located on the side of the instrument case. To access the fuse, push the cap in and rotate counterclockwise.

7.0 TROUBLESHOOTING

WARNING

Shorting electrical components could result in serious electrical shocks, or could damage equipment. All electrical troubleshooting must be performed by a qualified electrician.

7.1 Instrument Will Not Calibrate: If the alarm sounds when test gas is applied but does not stop when gas is removed, or if response is very slow.

7.1.1 Calibration humidifier not moistened during calibration. Ensure that the humidifying media is dampened with distilled water before calibrating.

7.1.2 Replace sensor.

7.2 Intermittent Alarm: A pressure switch mounted on the circuit board monitors pressure of the sample-air delivered to the sensor. If pressure at the switch (which is monitored by flow through the flow meter) drops below minimum requirement, or rises above maximum psi, the monitor will initiate an intermittent alarm.

7.2.1 Before doing pressure tests, make sure the Run/Calibration toggle switch is toward "RUN" position. If for any reason the toggle is not in the "RUN" position, the instrument will initiate an intermittent alarm, indicating that the sample-air is not reaching the sensor. Correctly positioning the toggle will terminate the intermittent alarm.

7.2.2 Make sure the pressure of the sample-air is between 55 psi and 120 psi. If the sample-air is higher than 55 psi, the restriction is internal. Proceed as follows.

7.2.3 Check flow through the flow meter. If the flow ball is below .5 SCFH or above .9 SCFH adjust the internal pressure regulator accordingly, until the ball remains between .5 and .8 SCFH. The regulator was factory set slightly higher than the pressure switch and should rarely require adjustment. If the regulator pressure was outside the limits, the alarm will disengage as soon as the pressure is corrected. After the pressure is correctly set, close the faceplate.

7.2.4 Check internal instrumentation lines for breaks, kinks, or disconnection. If a line has come loose, reconnecting it will re-establish function and the monitor could be correctly used. NOTE: This type of failure

could be the result of improper service, as the instrument is tested with pressure much higher than operating pressure. The monitor should be returned to the maintenance service technician for review as soon as practical.

7.3 No annunciator lights or alarms. This condition indicates a loss of electrical power, as it is unlikely that audible and visual alarms will fail at the same time.

7.3.1 Make sure the electrical power cord is connected to the appropriate power source.

7.3.2 Check the fuse located inside the case; make sure it is not blown.

7.3.3 Check to make sure that the power supply is ON.

7.3.4 For 12-volt system, make sure the battery is fully charged and that the charging system is operational. Make sure the positive and negative terminals are connected correctly.

7.3.5 Check for faulty transformer, or loose plug connection on circuit board.

7.4 Either alarm light or audible alarm fails.

7.4.1 Check for loose plug connections on circuit board.

7.4.2 To test the alarm, remove the plug connection on the circuit board from the suspect alarm, and apply external 12-volt power. If the alarm fails to activate, replace it.

7.4.3 To test the circuit board, remove the plug connection from the faulty alarm. Use a volt meter to check voltage across circuit board pins. Note: When testing an audible alarm, switch the Run/Calibration Switch to the "Calibration" position. This will cause an intermittent alarm, and should register on the voltmeter each time the alarm activates. Monitors with faulty circuit board should be returned for service.

8.0 ACCESSORIES AND REPLACEMENT PARTS

8.1 Accessories

Item	Description	Stock No.
(-)	Remote alarm kit, Includes: alarm, stand, wiring connector and 50 ft. cable	22909
(-)	Cable, 50 feet remote alarm extension	22910
(-)	Air line humidifier	03600

8.2 Replacement Parts

Item	Description	Stock No.
(-)	CMS-2 CO monitor package Includes: monitor, calibration connector, and 10 PPM test gas	
	120-volt AC	22894
	220-volt AC, 50/60-Hz	25531
	12-volt DC	25024
	120-Volt and 220-Volt AC monitors can be field-converted to 12-Volt DC. Refer to Section 2.3.	
(-)	CMS-2 CO monitor (instrument only)	
	120-volt AC	22892
	12-volt DC	25072
	220-volt 50/60-Hz	25532
	120-Volt and 220-Volt AC monitors can be field-converted to 12-Volt DC. Refer to Section 2.3.	
(-)	Calibration connector assembly	22893
(-)	Test gas, 10 PPM	22865
(-)	Test gas, impurity-free	11132
(-)	Sensor	22919
(-)	Regulator/filter	22920
(-)	Filter element.....	22921
(-)	Flow meter.....	21376
(-)	Horn w/ wire, (audible alarm) 12-volt DC ...	22922
(-)	Alarm light, exterior w/ wire & connector....	22923
(-)	Fitting, 1/4" OD quick fit	22924
(-)	Tubing, urethane, ten feet required	12475
(-)	Orifice, .004 purple restrictor	24423
(-)	Orifice, .006 red restrictor	24424