



CLEMCO
The Performance
System

TECHNICAL DATA SHEET

Note: For safe, efficient blasting, read and follow the owner's manual and seek training for everyone who will use this equipment.

Purpose

High-performance blast cleaning system removes corrosion, mill scale, and coatings from most surfaces. Produces a uniform surface texture, and creates a surface profile to increase bonding for coatings. See related literature for additional applications. Machine holds 2 cubic feet of abrasive for up to 30 minutes of continuous blasting at 100 psi with standard No. 4 nozzle ($1/4$ -inch orifice).

Requirements for Operation

These items are required but not included with this equipment.

- Clean, dry, compressed air of sufficient volume to maintain desired pressure at the nozzle. See Air Consumption Chart in Blast Off 2 booklet.
- Maximum working pressure 150 psi
- Minimum pressure 30 psi needed to operate OSHA-required remote control valves
- NIOSH-approved supplied-air respirator
- Grade D breathing-air supply as defined by the Compressed Gas Association Commodity Specification: G-7.1 (www.cganet.com)
- Abrasive blast media - consult abrasive supplier for appropriate media for your application
- Blast suit and work boots

Description of Operation

The operator controls blasting from a remote control handle at the nozzle. Pressing the handle starts blasting, releasing it stops blasting. The blast machine contains abrasive and meters it into the compressed air stream.

Description

Field portable, high-production, single-chamber blast machine, rated at 150 psi, (for one operator). Holds 2 cubic feet of blast media. Equipped with Millennium pneumatic remote controls and Quantum manual metering valve.

2 Cu Ft Contractor Blast Machine

Stock No. 21490



Advantages

- Rated for 150-psi maximum working pressure
- $1\frac{1}{2}$ -inch Millennium valve provides unrestricted air flow
- Quantum metering valve maintains smooth, consistent flow, adjustment knob allows precise control of media flow
- 29-inch width fits through standard doorways
- Two-wheel integral cart for ease of moving
- Robust handles act as skid for loading machine into pickup or trailer and protect valves and piping from damage.
- Central hookup point for blast hose and remote controls
- Weather-resistant storage area holds manuals, paperwork and small parts

Approvals and Certifications

Blast machine pressure vessel built to American Society of Mechanical Engineers (ASME) code for 150-psi working pressure. Vessel is hydrostatically tested and National Board certified.

Remote control system complies with OSHA regulation 1910.244 (b).

Related Clemco Literature

Description	Stock No.
Contractor Series Catalog	21385
Abrasive Blasting Safety Practices	22090
Blast Off 2	09294
Contractor Blast Machine Owner's Manual	21939

Options & Accessories

Description	Stock No.
Blast machine cover, 16"	02335
Blast machine screen, 16"	03099
Supa blast hose, 1" x 50 ft, coupled w/NHP-1 & CQPS-1 ...	23480
TMP-4 nozzle.....	23520
1" air filter/moisture separator w/manual drain	22424
Blast hose safety cable	15013
Apollo 600 HP DLX respirator, Clem-Cool air conditioner, and 50 ft x 3/8" respirator hose.....	25208
CPF-20 air filter w/pressure regulator & gauge	03578
Carbon monoxide alarm, CMS-3 pkg	24612
Heavy cotton/leather blast suit S (08920), M (08921), L (08922), XL (08923), 2XL (24201), 3XL (24202)	

Item Description	Stock No.
Seasonal cotton/nylon blast suit S (22913), M (22914), L (22915), XL (22916), 2XL (22917), 3XL (25022), 4XL (24689)	
Leather gloves	02243

Included with Stock No. 21490

Item Description	Stock No.
1. 2 cu ft contractor blast machine.....	21490
2. 1 1/2" Millennium valve.....	21336
3. Quantum abrasive metering valve	22845
4. Abrasive trap	02011
(-) RLX pneumatic handle.....	10565
(-) 50 ft twinline hose	01951

Installation Dimensions

A-1 - Floor to center of inlet pipe	24 ³ / ₈ "
A-2 - Floor to center of hose coupling.....	3 ¹ / ₄ "
A-3 - Width - outside handles	19 ¹ / ₄ "

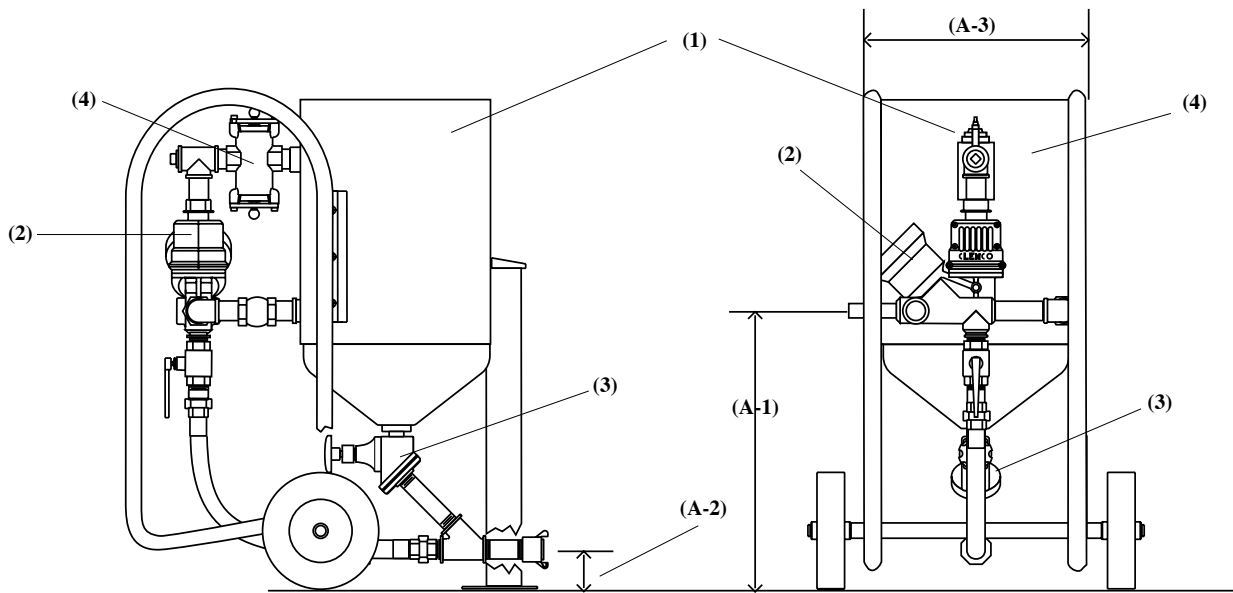

Nominal Dimensions

	Unit	Shipping (including skid)
Height (floor to highest point):	44"	49"
Width (outside hub to hub):	29"	35"
Length (hose cplg. to handle):	39"	40"
Machine diameter:	16"	
Net weight:	258 lb	
Shipping Volume:		39.7 cu ft
Shipping Weight:		326 lb

Packaging

Secured on skid and shrink wrapped

Authorized Distributor:



ISO 9001:2008 certified. Clemco is committed to continuous product improvement. Specifications are subject to change without notice.

© 2013 Clemco Industries Corp. • One Cable Car Drive • Washington, MO 63090 • Phone (636) 239-4300 • Fax (800) 726-7559